



**Diavia**

---

**FIAT SCUDO  
2.0 MJT**

---

*Montaggio compressore*

---

*Pose compresseur*

---

*Compressor installation*

---

*Einbau des Kompressors*

---

*Montaje compresor*

**Codice/Code: 7FI270 (A07FI270)**

---

**Istruzioni di montaggio**

**Instructions pour le montage**

**Fitting instructions**

**Einbauanleitungen**

**Instrucciones de montaje**



**DELPHI ITALIA AUTOMOTIVE SYSTEMS S.r.l. "Stabilimento Molinella"**

Via Nobili, 2 40062 Molinella (Bologna) - Italy

Telefono (0039) 051.6906111 - Fax (0039) 051.6906287 - Email: [diavia.service@delphi.com](mailto:diavia.service@delphi.com)

**DESCRIZIONE SIMBOLOGIA UTILIZZATA / DESCRIPTION DE LA SYMBOLOGIE UTILISÉE  
DESCRIPTION OF SYMBOLS USED / BESCHREIBUNG DER VERWENDETEN SYMBOLIK  
DESCRIPCIÓN DE LOS SIMBOLOS UTILIZADOS**

1A

Riferimento a figura / Référence à la figure / See figure  
In Bezug auf Abbildungen / Referencia a la figura

1-1

Riferimento a componenti di fornitura / Référence aux composants de la fourniture  
See supplied components / Bezug auf Gelieferte Einbauelemente  
Referencia a los componentes de abastecimiento

1

Riferimento a posizione schema elettrico / Référence à la position du schéma électrique  
See position in wiring diagram / In Bezug auf Position im Schaltschema /  
Referencia a la posición del esquema eléctrico



- Lubrificare tutti i raccordi e gli O.R. con il nuovo olio refrigerante prima di collegarli

- Graisser tous les raccords et les O.R. avec le nouveau huile réfrigérant avant de les raccorder

-Lubricate all fittings and O-rings with new refrigerant oil before connecting them

- Alle Verbindungsstücke und OR-Ringe vor deren Verbindung mit dem neuen Kühlmittellöl ölen

- Lubrificar todos los empalmes y los O.R. con el nuevo aceite refrigerante antes de conectarlos

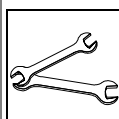

- Per avvitare a fondo o allentare i raccordi tubi gas usare due chiavi per bilanciare coppia di torsione

- Pour visser à fond ou desserrer les raccords des tuyaux gaz, utiliser le deux clés pour équilibrer le couple de torsion

- When tightening or loosening the fittings of the gas pipes, use two wrenches to equalize the torsion couple

- Um die Verbindungsstücke der Kältemittelschläuche gleichmäßig festzuschrauben oder zu lockern, zwei Schlüssel für das Verschraubungspaar verwenden

- Para enroscar a fondo o aflojar los empalmes tubos gas se deben usar dos llaves para balancear el par de torsión



- Tagliare con utensile appropriato al materiale

- Couper à l'aide d'outil approprié

- Cut with a device suitable for the material

- Mit dem Material entsprechendem Werkzeug schneiden

- Cortar con herramienta apropiada al material

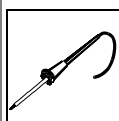

- Stagnare

- Étamer

- Tin

- Verzinnen

- Estañar



- Spianare

- Nivelar

- Flatten out

- Richten

- Nivelar

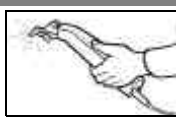

- Tagliare con utensile a lama calda

- Couper à l'aide d'un outil à lame chaude

- Cut using the tool with heated blade.

- Mit Schweißmesserwerkzeug schneiden

- Cortar con útil a hoja caliente

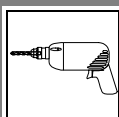

- Forare

- Percer

- To drill

- Durchbohren

- Taladrar

Pos.	ITALIANO	FRANÇAIS	ENGLISH	DEUTSCH	ESPAÑOL
1	Piastra supporto compressore	Plaque support compresseur	Compressor support plate	Kompressorträger	Placa soporte compresor
2	Compressore	Compresseur	Compressor	Kompressor	Compresor
2.1	Cablaggio PACKARD per compressore	Câblage PACKARD pour compresseur	PACKARD wiring for compressor	PACKARD Kabelstrang für Kompressor	Cableado PACKARD para compresor
3	Distanziale	Entretoise	Shim	Absandsstück	Distanziador
4	Tirante	Tirant	Tie-rod	Verbindungsstange	Tirante
5	Cinghia	Courroie	Belt	Riemen	Correa
6	Bulloneria	Boulonnerie	Nuts and bolts	Schraubensatz	Tornillería
7	Dima di foratura	Gabarit de perçage	Drilling template	Bohrungsschablone	Patrón de taladrado

**MONTAGGIO COMPRESSORE / POSE DU COMPRESSEUR / COMPRESSOR FITTING  
KOMPRESSOREINBAU / MONTAJE COMPRESOR**

MATERIALE FORNITO / MATERIEL FOURNI / SUPPLIED MATERIAL / GELIEFERTES MATERIAL / MATERIAL ABASTECIDO

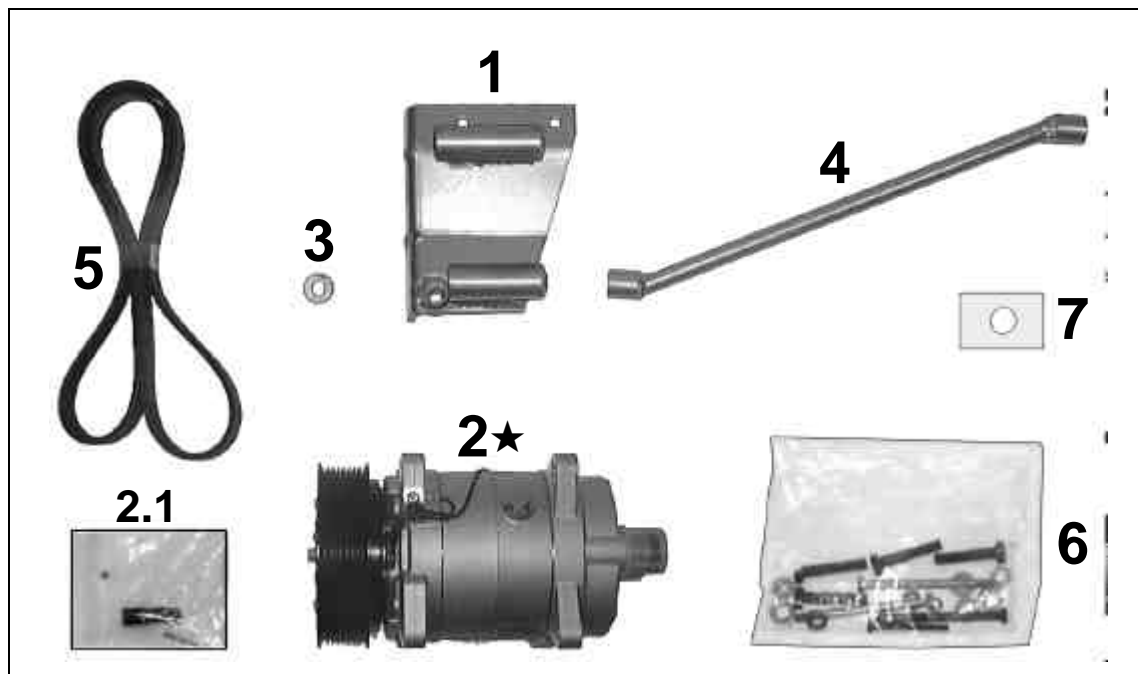

**7FI270 (A07FI270)**

1A

*Componente d'acquisto a cura dell'installatore, non inserito nel KIT A07FI270*

*Composant à acheter par l'installateur, non fourni dans le Kit A07FI270*

★ *Component to be purchased by the installer. Not included in KIT A07FI270*

*Nicht im Einbausatz A07FI270 enthaltene und vom Einbauer separat zu kaufende Einbauteile  
Componente de compra a cargo del instalador, no incluido en el Kit A07FI270*

Pos.	Descrizione / Description / Description / Beschreibung / Descripción	Codice / Code Kode / Código
1	Piastra supporto compressore	0011255/0
2★	Compressore	015201/1
2.1	Cablaggio PACKARD per compressore	0282113/1
3	Distanziale $\phi 10 \times \phi 22 \times 10$	009138ZN
4	Tirante	0021823/0
5	Cinghia 6Kx1275	013696/0
6	Bulloneria	037FI270
7	Dima di foratura	079178/0

**FORI DI FISSAGGIO / TROUS DE FIXATION / SECURING HOLES  
BEFESTIGUNGSBOHRUNGEN ORIFICIOS DE FIJACIÓN**

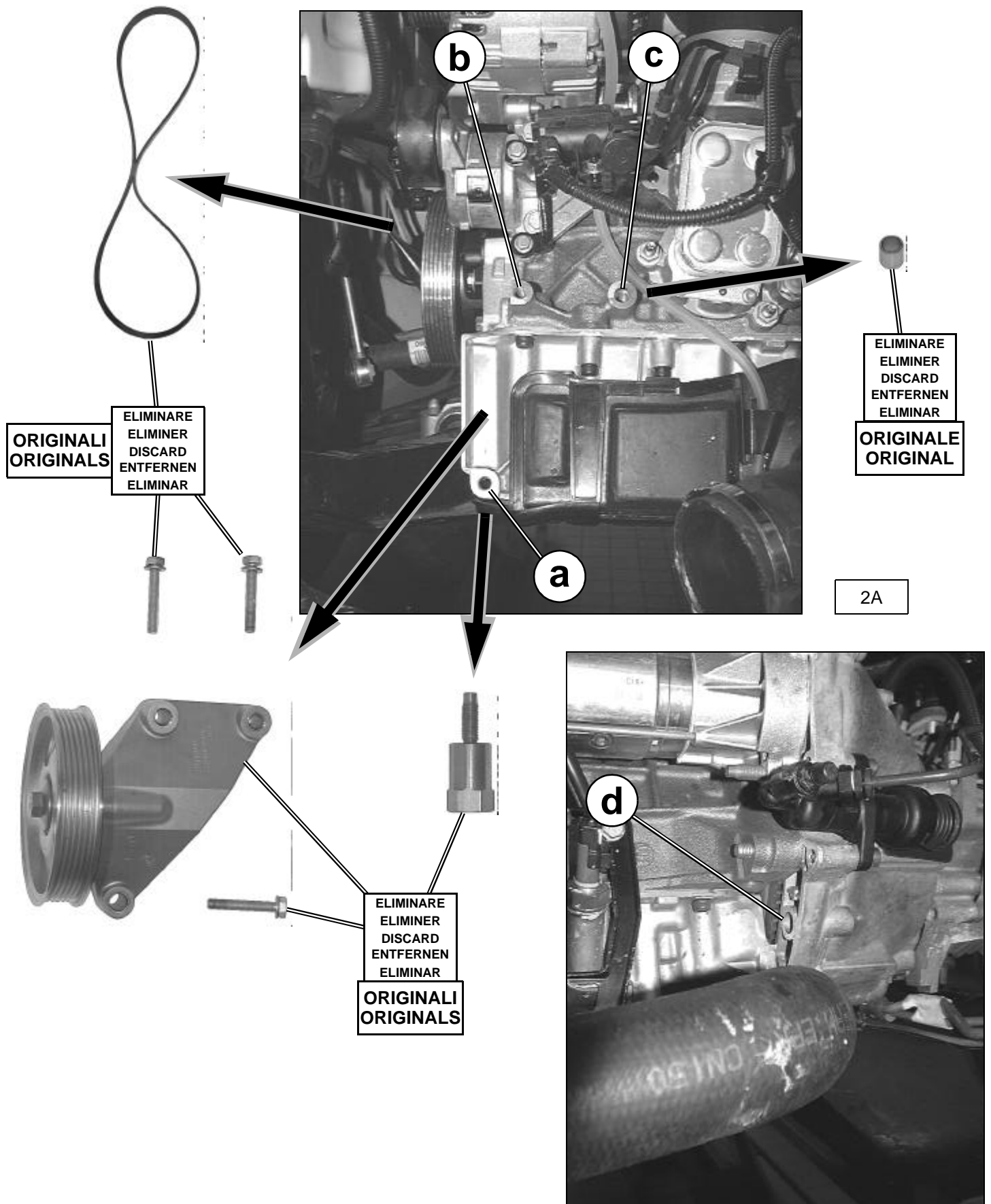

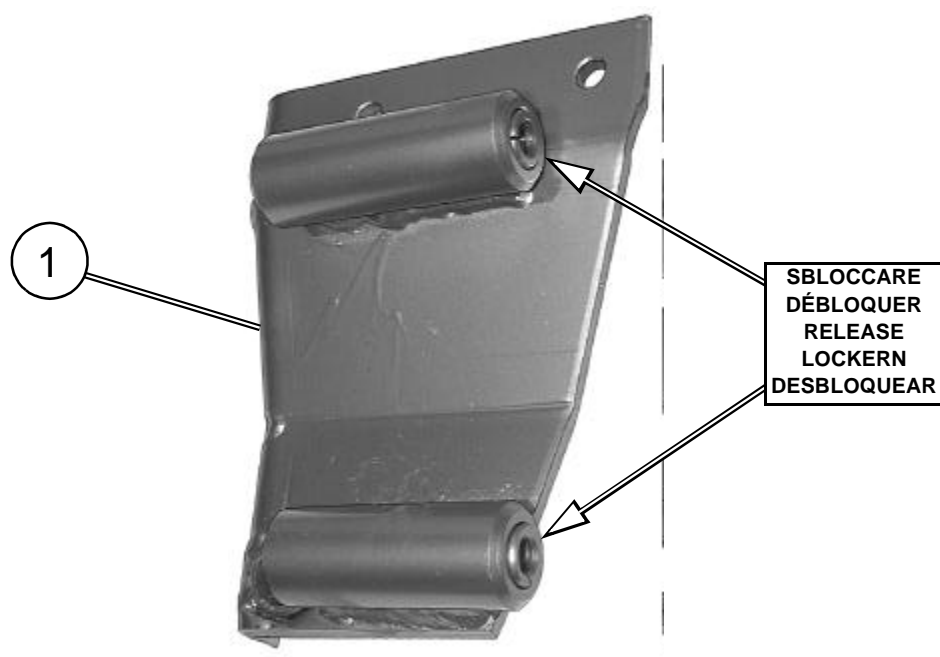

3A

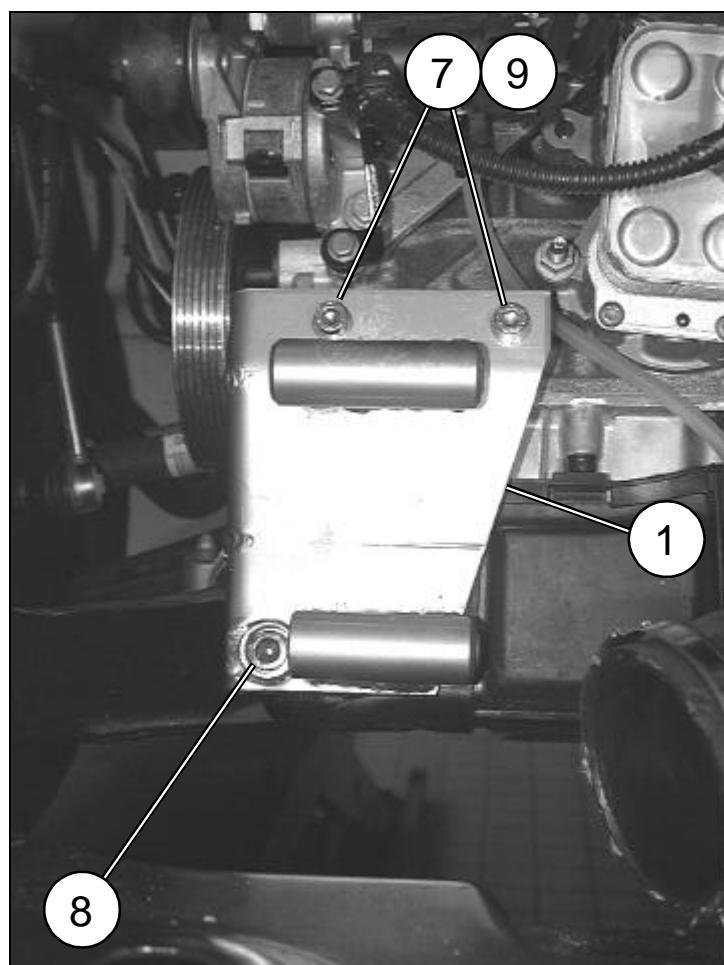

BULLONERIA DA UTILIZZARE BOULONNERIE A UTILISER NUTS AND BOLTS TO BE USED ZU BENUTZENDER SCHRAUBENSATZ TORNILLERIA A UTILIZAR		
Pos.	Tipologia Typologie Typology Tipologie Tipologia	Descrizione Description Description Beschreibung Descripción
7		M8x30
8		M10x35
9		φ 8

(I)

**ATTENZIONE:** Qualora si decida per il funzionamento dell'impianto di refrigerazione con utilizzo di fluido refrigerante "R404a" (funzionamento di refrigerazione con temperature negative), prima di installare il compressore è necessario svuotare tutto l'olio in esso contenuto e sostituirlo con olio appropriato fornito.

(F)

**ATTENTION:** Dans le cas où l'on décide pour le fonctionnement de l'installation de réfrigération l'utilisation du fluide réfrigérant "R404a" (fonctionnement de réfrigération avec des températures négatives), avant d'installer le compresseur il faut le vider de toute l'huile qu'il contient et la remplacer par de l'huile appropriée fournie.

(GB)

**WARNING:** If the refrigeration system is to be operated using "R404a" refrigerant fluid (refrigeration operating with negative temperature), before installing the compressor, empty out all oil contained in the compressor and replace it with the appropriate oil supplied.

(D)

**ACHTUNG:** Sollte für die Inbetriebnahme der Kühlungsanlage Kühlmittel "R404a" verwendet werden (Kühlungsfunktion mit Minus-Temperaturen) vor dem Einbau des Kompressors das darin befindliche Öl vollständig entleeren und dieses mit dem dafür geeigneten gelieferten Öl ersetzen.



(E)

**ATENCIÓN:** Si se decide por el funcionamiento de la instalación de refrigeración y utilizar fluido refrigerante "R404a" (funcionamiento de refrigeración con temperaturas negativas), antes de instalar el compresor es necesario vaciar todo el aceite que tiene dentro y sustituirlo con el aceite apropiado que se entrega.

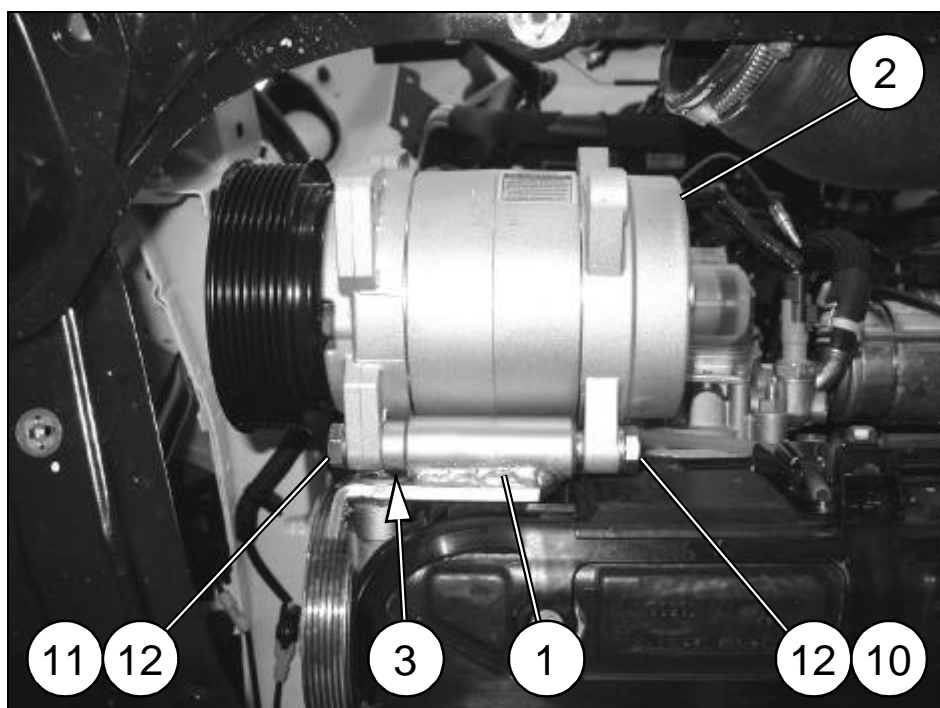
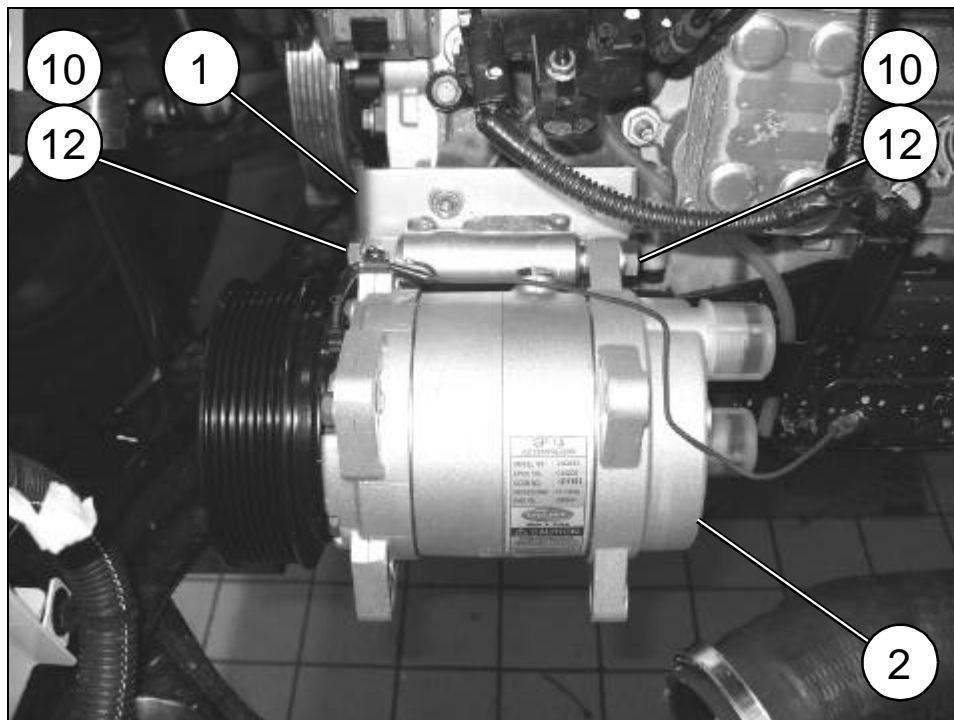

4A

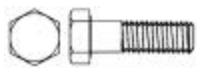
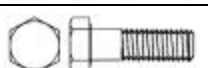

BULLONERIA DA UTILIZZARE / BOULONNERIE A UTILISER / NUTS AND BOLTS TO BE USED ZU BENUTZENDER SCHRAUBENSATZ / TORNILLERIA A UTILIZAR			
Pos.	Tipologia / Typologie / Typology Typologie / Tipologia	Descrizione / Description / Description Beschreibung / Descripción	Codice / Code Code / Código
3		Distanziale	009138ZN
10		M10x35	-
11		M10x45	-
12		φ 10	-

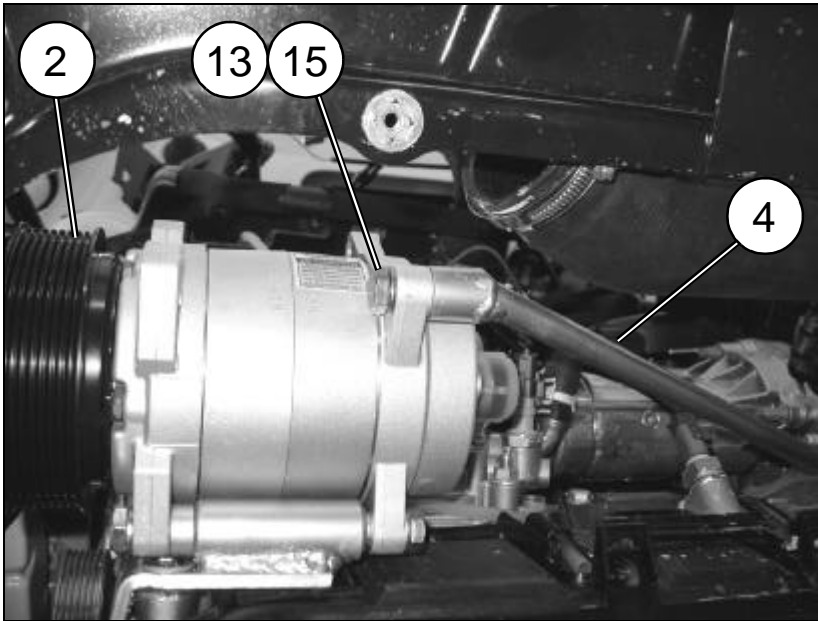

(I) **ATTENZIONE:** ricollegando il manicotto aria "M" all'intercooler, verificare che il medesimo risulti distante almeno 10mm dal corpo del compressore.

(F) **ATTENTION:** en raccordant le manchon de l'air "M" au refroidisseur, s'assurer qu'il se trouve à au moins 10mm du corps du compresseur.

(GB) **WARNING:** when reconnecting the air pipe "M" to the intercooler, check that it is at least 10mm from the compressor body.

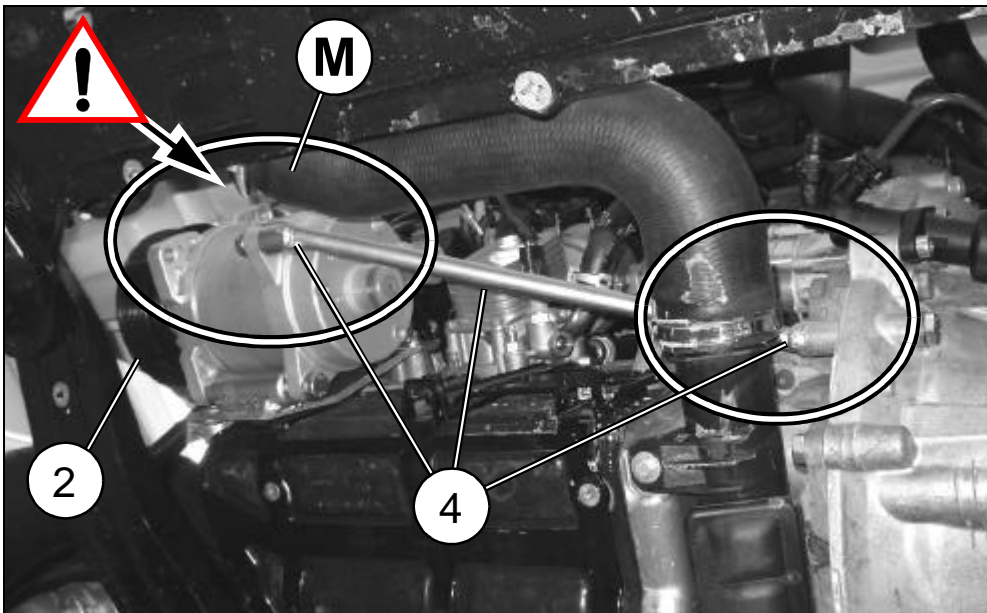

(D) **ACHTUNG:** Beim erneuten Anschluss der Luftmuffe "M" an den Intercooler überprüfen, dass diese mindestens 10mm vom Kompressorgehäuse entfernt resultiert.

(E) **ATENCIÓN:** Cuando se vuelva a conectar el manguito aire "M" al intercooler, comprobar que éste se encuentre a una distancia de al menos 10mm. del cuerpo del compresor.

5A

BULLONERIA DA UTILIZZARE BOULONNERIE A UTILISER NUTS AND BOLTS TO BE USED ZU BENUTZENDER SCHRAUBENSATZ TORNILLERIA A UTILIZAR		
Pos.	Tipologia / Typologie Typology / Tipologie Tipologia	Descrizione / Description Description / Beschreibung Descripción
13		M10x30
14		M10x60
15		φ 10

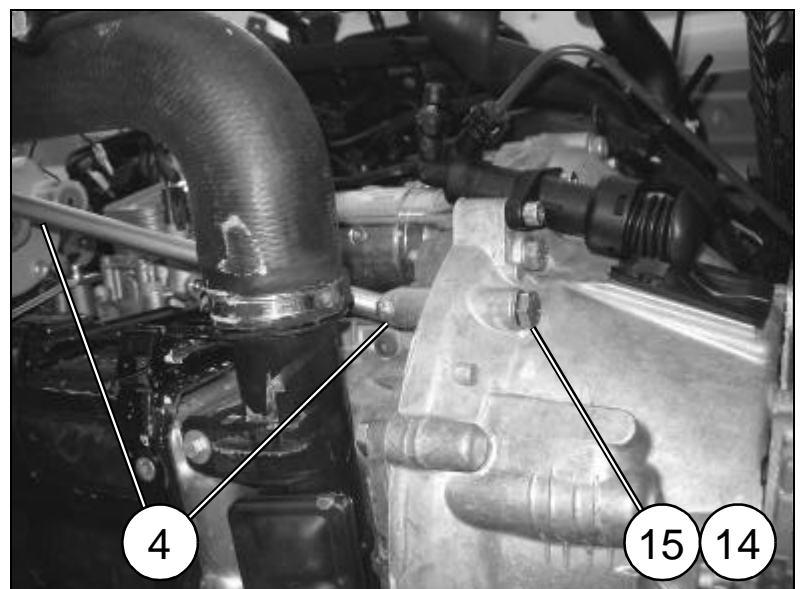



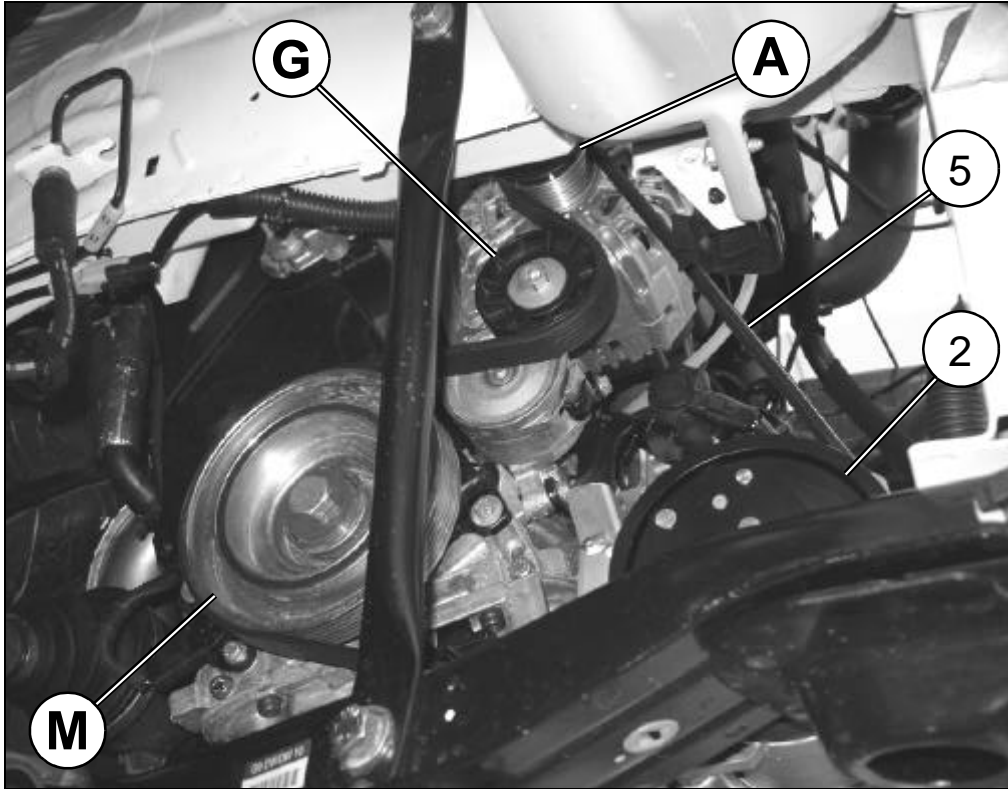

6A

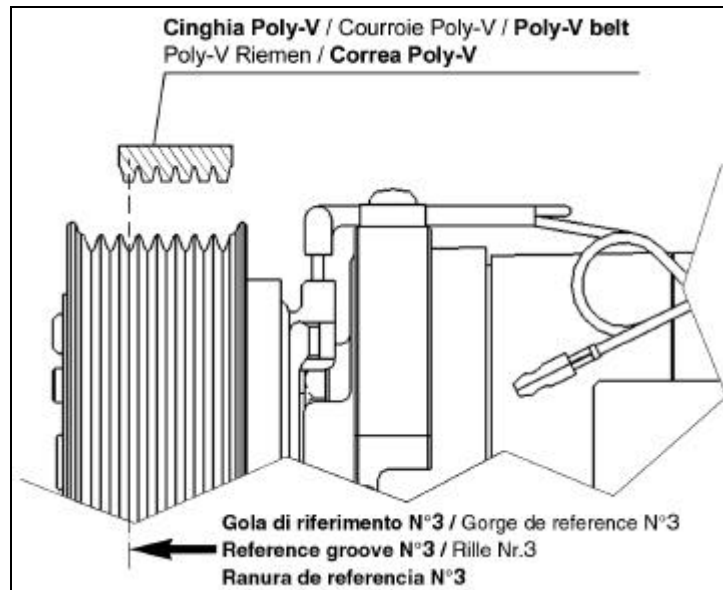

**OPERAZIONE DI MODIFICA POSIZIONE INTECOOLER  
OPERATION DE MODIFICATION INTERCOOLER  
INTERCOOLER POSITION MODIFICATIONS  
ARBEITSCHRITTE ZUR ABÄNDERUNG DER INTERCOOLER-POSITION  
OPERACIÓN DE MODIFICACIÓN POSICIÓN INTERCOOLER**

**ATTENZIONE:** Nel caso si verificano interferenze tra il compressore e il maniccotto aria inferiore dell'intercooler è necessario eseguire le operazioni di seguito riportate, dopo aver rimosso momentaneamente l'intercooler.

**ATTENTION:** S'il se produit des interférences entre le compresseur et le manchon à air inférieur du refroidisseur intermédiaire, il faut effectuer les opérations indiquées ci-après, après avoir enlevé temporairement le refroidisseur intermédiaire.

**WARNING:** If there is interference between the compressor and lower intercooler air pipe, temporarily remove the intercooler and perform the operations indicated below.

**ACHTUNG:** Sollte Kontakt zwischen dem Kompressor und dem unteren Luftschlauch des Intercoolers entstehen, den Intercooler kurz ausbauen und die in der Folge beschriebenen Schritte befolgen.

**ATENCIÓN:** En caso de que se verifiquen interferencias entre el compresor y el manguito de aire inferior del intercooler, es necesario llevar a cabo las operaciones descritas a continuación, tras haber quitado momentáneamente el intercooler.

7A

**SMONTARE E CONSERVARE  
DEMONTET ET GARDER  
REMOVE AND KEEP  
AUSBAUEN UND AUFBEWAHREN  
DESMONTAR Y CONSERVAR**

**ORIGINALE  
ORIGINAL**

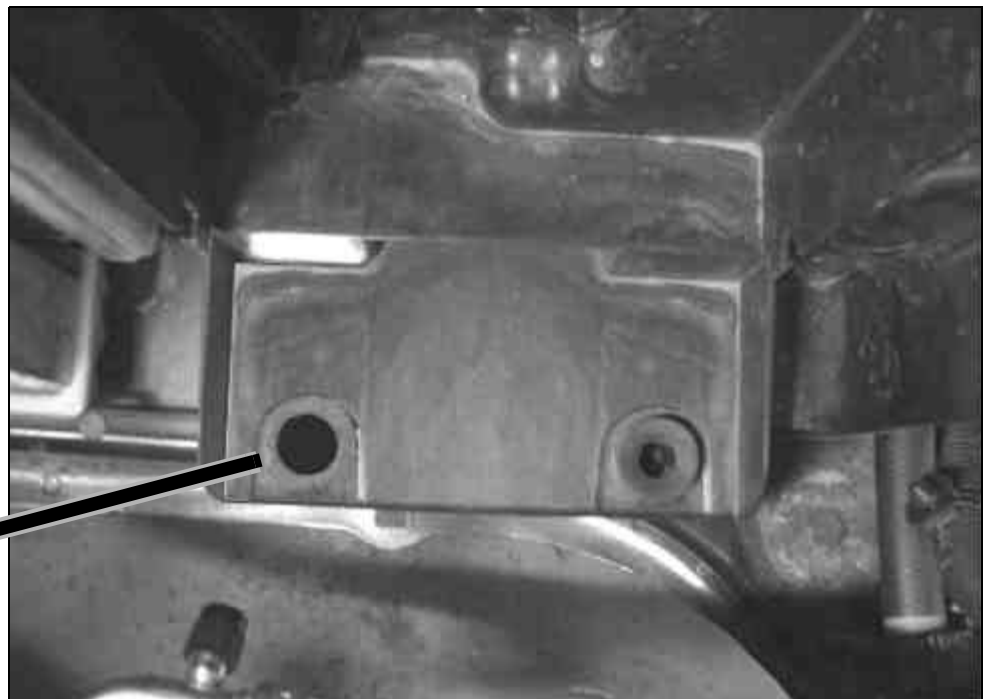

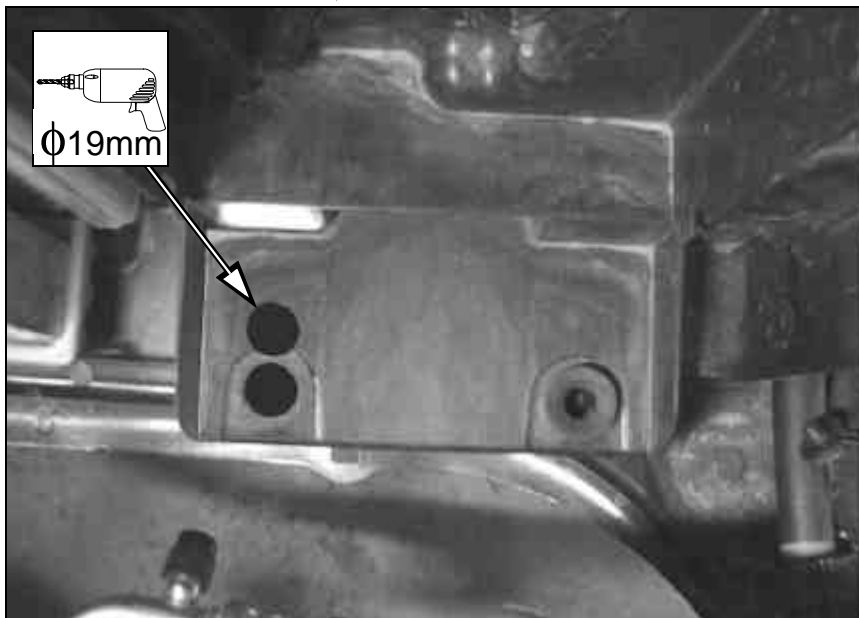
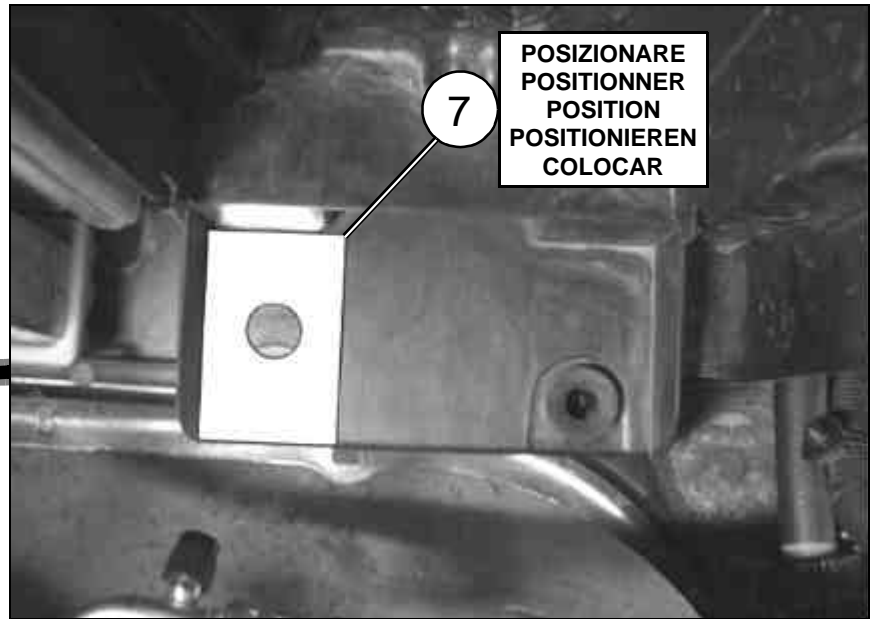

8A



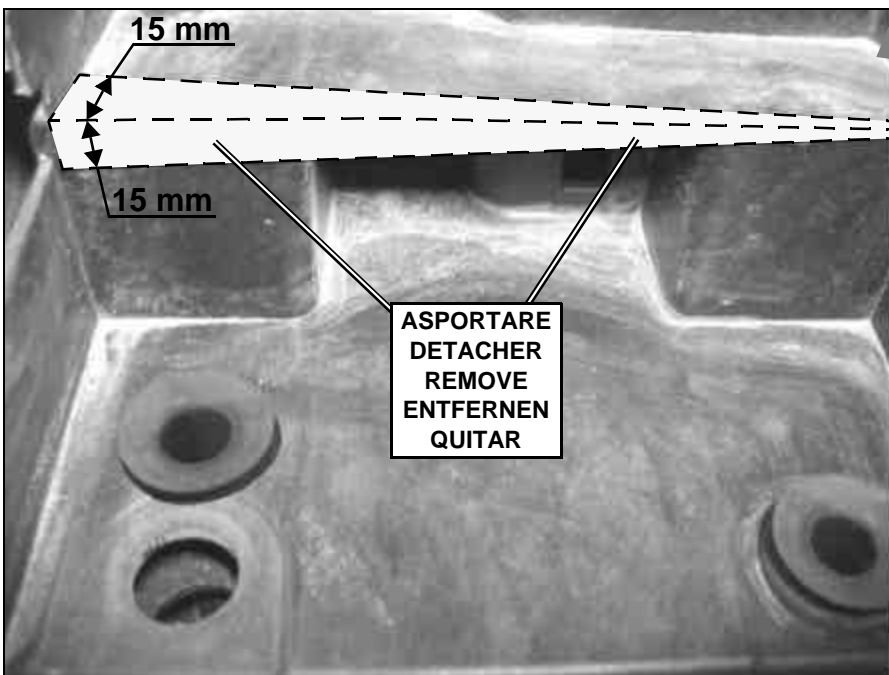
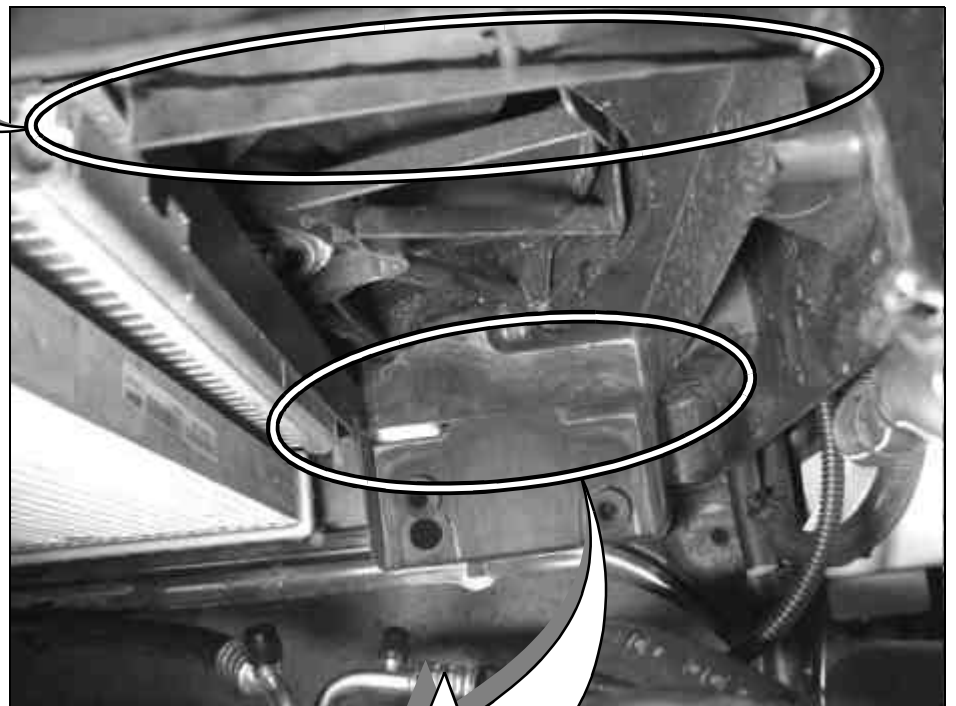
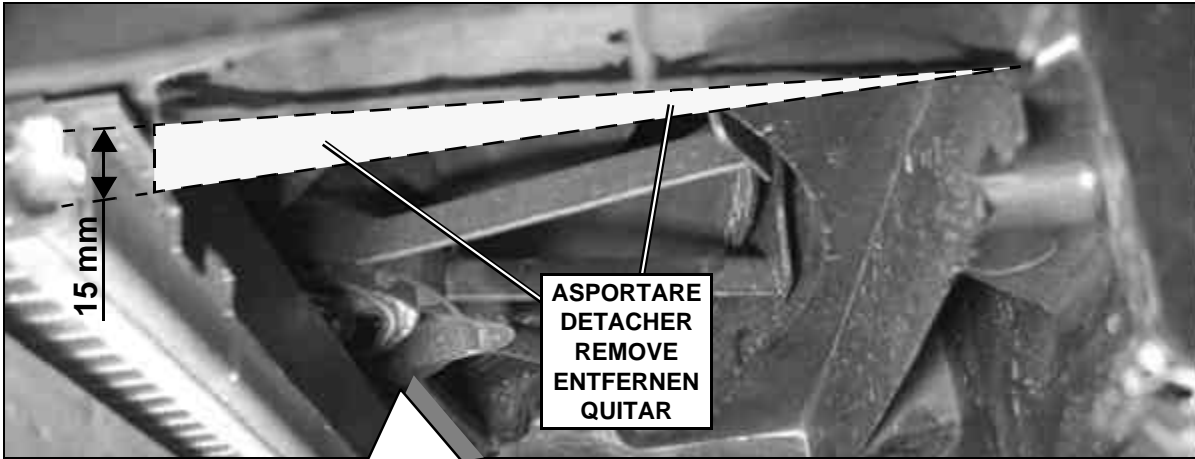

**(I)**  
DELPHI ITALIA mira ad un costante miglioramento dei propri prodotti. La Casa si riserva il diritto di apportare in qualunque momento e senza preavviso modifiche ai modelli e ai componenti descritti in questa pubblicazione per ragioni di natura tecnica o commerciale. Per ulteriori informazioni rivolgersi al servizio assistenza DELPHI.

**(F)**  
DELPHI ITALIA vise à une amélioration constante des ces produits. La maison se réserve le droit d'apporter, à tout moment et sans préavis, des modifications aux modèles et aux composants décrits dans cette publication pour des raisons d'ordre technique ou commerciale. Pour d'ultérieures informations s'adresser au service d'assistance DELPHI.

**(GB)**  
DELPHI ITALIA focuses on constant upgrading of its products. The Manufacturer reserves the right to modify the models and components described in the present publication at any time for technical or commercial reasons and without prior notice. For further information, contact DELPHI technical services.

**(D)**  
DELPHI ITALIA ist stets bestrebt die eigenen Produkte zu verbessern. Die Herstellerfirma behält sich das Recht vor, aus technischen oder Verkaufsgründen, zu jeder Zeit und ohne vorherige Ankündigung, Abänderungen an den Modellen und den in dieser Veröffentlichung beschriebenen Einbauteile vorzunehmen. Für weitere Informationen bitten wir Sie, sich an unseren DELPHI Kundendienst zu wenden.

**(E)**  
DELPHI ITALIA aspira a un constante mejoramiento de su producción. La Fábrica se reserva el derecho de aportar en cualquier momento y sin preaviso modificaciones a los modelos y los componentes descritos en esta publicación por razones técnicas o comerciales. Para ultiores informaciones dirigirse al servicio asistencia DELPHI.

VENDITA E SERVIZIO  
VENTE ET SERVICE

VERKAUF UND SERVICE  
SALE AND SERVICE

**DELPHI ITALIA AUTOMOTIVE SYSTEMS S.r.l.**  
**Stabilimento Molinella**

Via Nobili, 2 40062 Molinella (Bologna)-Italy  
Telefono (0039) 051.6906111

Fax (0039) 051.6906287

Email: [diavia.service@delphi.com](mailto:diavia.service@delphi.com)

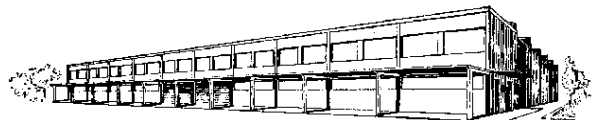

MOD. SCHFI372/1

IV / '09  
(2007)

Questa pubblicazione è stata curata da DELPHI ITALIA-Diavia  
Ufficio Fitting Instructions - Stabilimento Molinella

This publication has been edited by DELPHI ITALIA-Diavia  
Fitting Instructions Office - Factory Molinella