

BBA54 / BBA54-12

Remote Stereo Amplifier

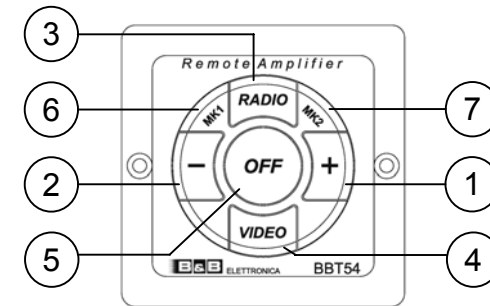

Operating instructions

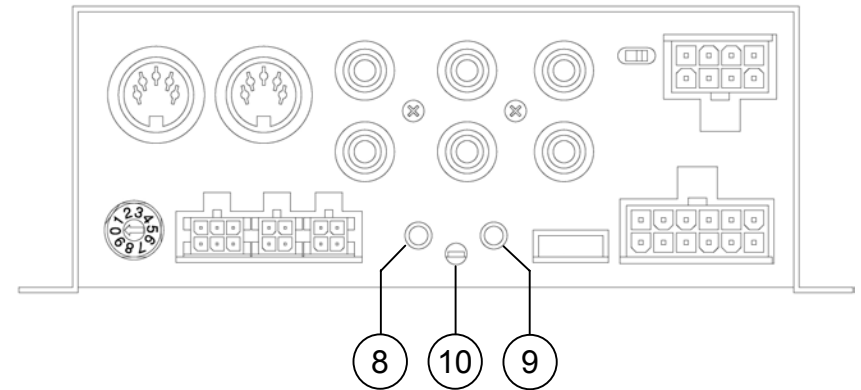

1	+	volume +
2	-	volume -
3	RADIO	select radio + power-on for amplifier
4	VIDEO	select video + power-on for amplifier
5	OFF	amplifier off
6	MK1	microphone 1 operating light
7	MK2	microphone 2 operating light
8	GAIN -	reduce gain
9	GAIN +	increase gain
10	LED	LED light

B & B elettronica srl
 41100 MODENA (Italy) - Via Malavolti, 49
 Tel. +39 059 254575 Fax. +39 059 254636
www.bbelettronica.it e-mail: bb@bbelettronica.it

General Features

A new concept Digital Stereo Amplifier for vehicles, with significant technological innovations. All functions are controlled by a micro-controller. Audio inputs (Radio-Video) and volume control. It may be connected to any model/brand of Radio-Tape/CD player, which it also supplies power voltage to. Power-on for video system. Two microphone inputs with independent volume control and priority over all other sources. RS485 dual serial port (interfaceable with CAN systems) to integrate into the vehicle devices and to dialogue with different B&B devices. Can be cascade-linked to more amplifiers to create different listening zones. Compact, versatile and easy to install. Works independently, connected to other (B&B) amplifiers or with the (BBT54) appropriate command keypad which enables direct source selection and volume adjustment. Its small size means it fits easily into any part of the vehicle.

Caution

It is recommended to carefully read through the instructions, prior to setting this device in operation; a thorough understanding of the basics means an easier utilization of this device.

Please, follow the instructions to carry out the "BBA54" amplifier connections:

chapter 4 CONNECTIONS

chapter 5 DIAGRAMS OF CONNECTION

Index

1 Technical specifications	17-18
2 Operating without the keypad	19
2.1 Power-on and off	
2.2 Inputs / Functionality	
3 Operating with the keypad	20
3.1 Power-on and off	
3.2 Inputs / Functionality	
4 Connections	21
5 Diagrams of connection	22÷26

BBA54 Technical Specifications

ALC = Automatic Level Control (only active when the keypad is connected)

Exclusive circuit controlled by micro-processor. It continuously analyses and corrects the input signal amplitude changes (50÷600mV), thus keeping constant the set amplitude level.

ELS = Electronic Loop Separator

Advanced circuit with differential input, it stops any noise from GND non suitable connections.

Main Specs	
Voltage rating	28 Vdc (18÷32 Vdc)
Absorbed current	5 A max
Safeties	Short circuit on all outputs Reversed polarity on power input Voltage surge - Under-voltage (Load Dump 150 Vp - 300 ms)
Operating temperature	0 +70 °C
Storage temperature	-40 +85 °C
Sizes (L x H x D)	155 x 70 x 60 mm
Weight	0,750 Kg
Inputs	
Radio power	1÷12 V RMS on 200 Ohm ALC + ELS
Radio-Video	50÷600 mV RMS on 2,2 kOhm ALC + ELS
Mikes level	1 mV RMS on 680 Ohm ELS
Common-mode rejection	> 60 db (10 Hz - 1 MHz)
Inputs separation	> 55dB (100 Hz - 10 kHz)
Video	mono-stereo selection
REM In Radio and Video	8 Vdc min 32 Vdc max
DC Outputs	
V out rating	13.8 Vdc ± 5% - 4 A max
REM Out	13.8 Vdc ± 5% - 500 mA max
AC Outputs	
Power OUT	2x25 W RMS (4 Ohm - THD 10%)
Audio Pre Out	350 mV RMS with max volume ALC
Passband	20÷20000 Hz (4 Ohm - 18 W THD 1%)
S/N ratio	> 65 dB (closed inputs - 100 Hz - 10 kHz)
Power noise rejection	> 70 dB (100 Hz - 10 kHz)
Video relays contacts	5 A max
BBT54 Keypad (powered by the amplifier)	
Sizes: 51 x 51 x18 mm	Weight: 45 g

BBA54-12 Technical Specifications

ALC = Automatic Level Control (only active when the keypad is connected)
 Exclusive circuit controlled by micro-processor. It continuously analyses and corrects the input signal amplitude changes (50÷600mV), thus keeping constant the set amplitude level.

ELS = Electronic Loop Separator

Advanced circuit with differential input, it stops any noise from GND non suitable connections.

Main Specs	
Voltage rating	13,8 V DC (10÷16V)
Absorbed current	7 A max
Safeties	Short circuit on all outputs Reversed polarity on power input Voltage surge - Under-voltage (Load Dump 90 Vp - 300 ms)
Operating temperature	0 +70 °C
Storage temperature	-40 +85 °C
Sizes (L x H x D)	155 x 70 x 60 mm
Weight	0,750 Kg
Inputs	
Radio power	1÷12 V RMS on 200 Ohm ALC + ELS
Radio-Video	50÷600 mV RMS on 2,2 kOhm ALC + ELS
Mikes level	1 mV RMS on 680 Ohm ELS
Common-mode rejection	> 60 db (10 Hz - 1 MHz)
Inputs separation	> 55dB (100 Hz - 10 kHz)
Video	mono-stereo selection
REM In Radio and Video	8 Vdc min 32 Vdc max
DC Outputs	
V out rating	13.8 Vdc ± 5% - 4 A max (6 A peak)
REM Out	13.8 Vdc ± 5% - 500 mA max
AC Outputs	
Power OUT	2x25 W RMS (4 Ohm - THD 10%)
Audio Pre Out	350 mV RMS with max volume ALC
Passband	20÷20000 Hz (4 Ohm - 18 W THD 1%)
S/N ratio	> 65 dB (closed inputs - 100 Hz - 10 kHz)
Power noise rejection	> 70 dB (100 Hz - 10 kHz)
Video relays contacts	5 A max
BBT54 Keypad (powered by the amplifier)	
Sizes: 51 x 51 x18 mm	Weight: 45 g

Operating the BBA54 and BBA54-12 without the keypad 2

When power is supplied the amplifier (**BBA54** or **BBA54-12**) goes into standby mode and supplies power to the connected radio (Radio-Tape/CD). By supplying voltage to the REM-RADIO (switching on the radio) or REM-VIDEO (switching on the video system) or activating the microphones (MK1-MK2), the amplifier switches on. It is possible to adjust the gain of each active source individually. Adjustments remain in the memory even when the supply voltage is switched off. The REM-VIDEO has priority over the REM-RADIO, MK1 and MK2 have precedence over both of them and MK1 has priority over MK2. In the absence of these commands, the amplifier returns to standby.

Power-on and off 2.1

REM-RADIO (switching on the radio), REM-VIDEO (switching on the video system) or with MIKE1/MIKE2 being active, the amplifier is switched on. In the absence of these commands, standby mode is restored.

Inputs/Functionality 2.2

RADIO: input for Radio -Tape/CD

On switching on, the radio (Radio-Tape/CD) supplies voltage (REM-RADIO) to contact no. 2 of the "RADIO PW" connector of the determining amplifier: source on and source selection.

VIDEO: input for video system audio

Voltage (REM-VIDEO) supplied to contact no.10 of the "POWER" connector determines: switching on monitors, amplifier and source selection. The VIDEO input has priority over the RADIO.

Mikes: The amplifier is provided with two mike inputs (MK1-MK2) with priority over all other sources, mikes are switched on with their own switch, and are not dependent from the amplifier status (on or off).

Gain adjustment: Volume adjustment (in this configuration) depends on the sources connected to the amplifier. However, it is possible to set the desired gain for each active source, by using the (gain + or gain -) buttons on the amplifier. The red LED flashes during the adjustment phase. The gain values set remain in the memory even if the power is removed from the amplifier.

RS485 Serial: The RS485 dual serial port (MODBUS-RTU protocol) allows the amplifier (master) to dialogue with all B&B devices and with any other systems in existence. The peripheral units (slaves) identification is determined by the position of the decimal uniselector on board all B&B equipment.

Just assign a number (1÷7) to each **slave**. Please, note that the number "0" is assigned to the **master**.

3 Operating the BBA54 and BBA54-12 with the keypad

When power is supplied the amplifier (**BBA54** or **BBA54-12**) goes into standby mode and supplies power to the connected radio (Radio-Tape/CD). By pressing the relevant button for the required source (RADIO or VIDEO) or by activating the microphones (MK1 or MK2), the amplifier is switched on (MK1 has priority over MK2). In this mode it is possible to adjust the volume of each active source individually. Adjustments remain in the memory even when the supply voltage is switched off. To turn off the amplifier, press the OFF button, which restores it to standby mode.

3.1 Power-on and off

Select: Radio or Video to power-on the amplifier. The corresponding key will change color from **green** to **red**, the OFF esc one will change from **red** to **green**. Press the OFF key to power-off the amplifier.

3.2 Inputs/Functionality

RADIO: input for Radio-Tape/CD.

The amplifier supplies power to the connected radio.

Volume control is effected by pressing the buttons + or -, and remains in the memory even if even if the power is removed from the amplifier.

VIDEO: input for video system audio.

The amplifier controls the on/off switch of the monitors.

Volume control is effected by pressing the buttons + or -, and remains in the memory even if even if the power is removed from the amplifier.

Mikes: The amplifier is provided with two mike inputs (MK1-MK2) with priority over all other sources, mikes are switched on with their own switch, and are not dependent from the amplifier status (on or off).

Volume control is effected by pressing the buttons + or -, and remains in the memory even if even if the power is removed from the amplifier.

RS485 Serial: The RS485 dual serial port (MODBUS-RTU protocol) allows the amplifier (master) to dialogue with all B&B devices and with any other systems in existence. The peripheral units (slaves) identification is determined by the position of the decimal uniselector on board all B&B equipment.

Just assign a number (1÷7) to each **slave**. Please, note that the number "0" is assigned to the **master**.

CONNECTIONS

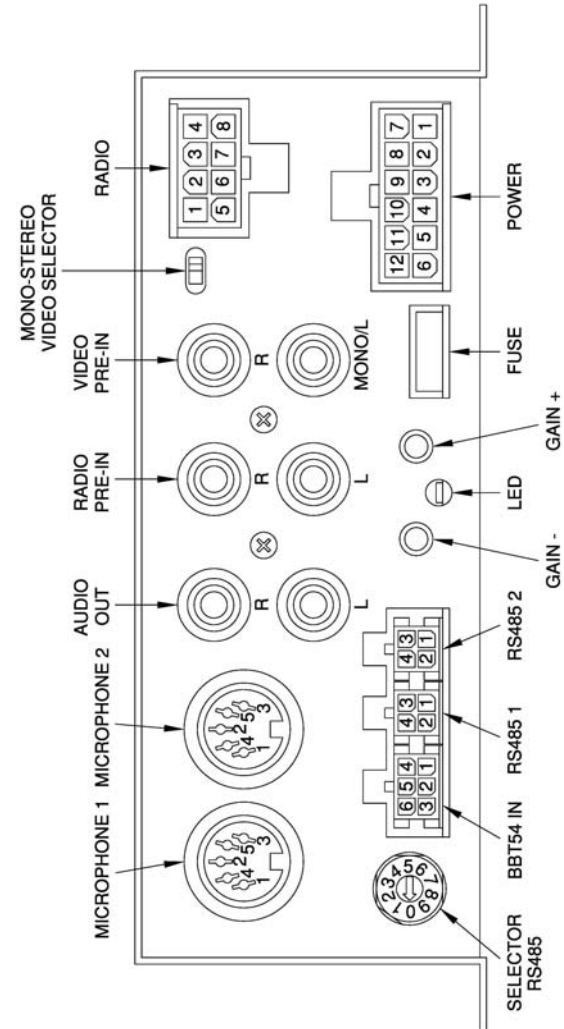

MICROPHONE 1-2		RS485 1-2		RADIO				POWER					
1	MICROPHONE +	1	GND	1	GND	1	LOUDSPEAKER L -	1	LOUDSPEAKER L -	4	REM-OUT	4	REM-OUT
4	MICROPHONE -	2	GND	2	REM-IN RADIO	2	LOUDSPEAKER L -	2	LOUDSPEAKER L -	10	REM-IN VIDEO	10	REM-IN VIDEO
2	SWITCH	3	B	3	LOUDSPEAKER-IN L -	3	LOUDSPEAKER R +	7	LOUDSPEAKER R +	5	+VDC IN (+30) PERMANENT	5	+VDC IN (+30) PERMANENT
5	SWITCH	4	A	4	LOUDSPEAKER-IN R -	4	LOUDSPEAKER R -	8	LOUDSPEAKER R -	11	+VDC IN (+15) IGNITION KEY	11	+VDC IN (+15) IGNITION KEY
3	NC			5	+12V OUT (+30) PERMANENT	5	+12V OUT (+30) PERMANENT	3	VIDEO ON SWITCH	6	GND	6	GND
				6	+12V OUT (+15) IGNITION KEY	6	+12V OUT (+15) IGNITION KEY	9	VIDEO ON SWITCH	12	GND	12	GND
				7	LOUDSPEAKER-IN L +	7	LOUDSPEAKER-IN L +						
				8	LOUDSPEAKER-IN R +	8	LOUDSPEAKER-IN R +						

BBA54-12 12V

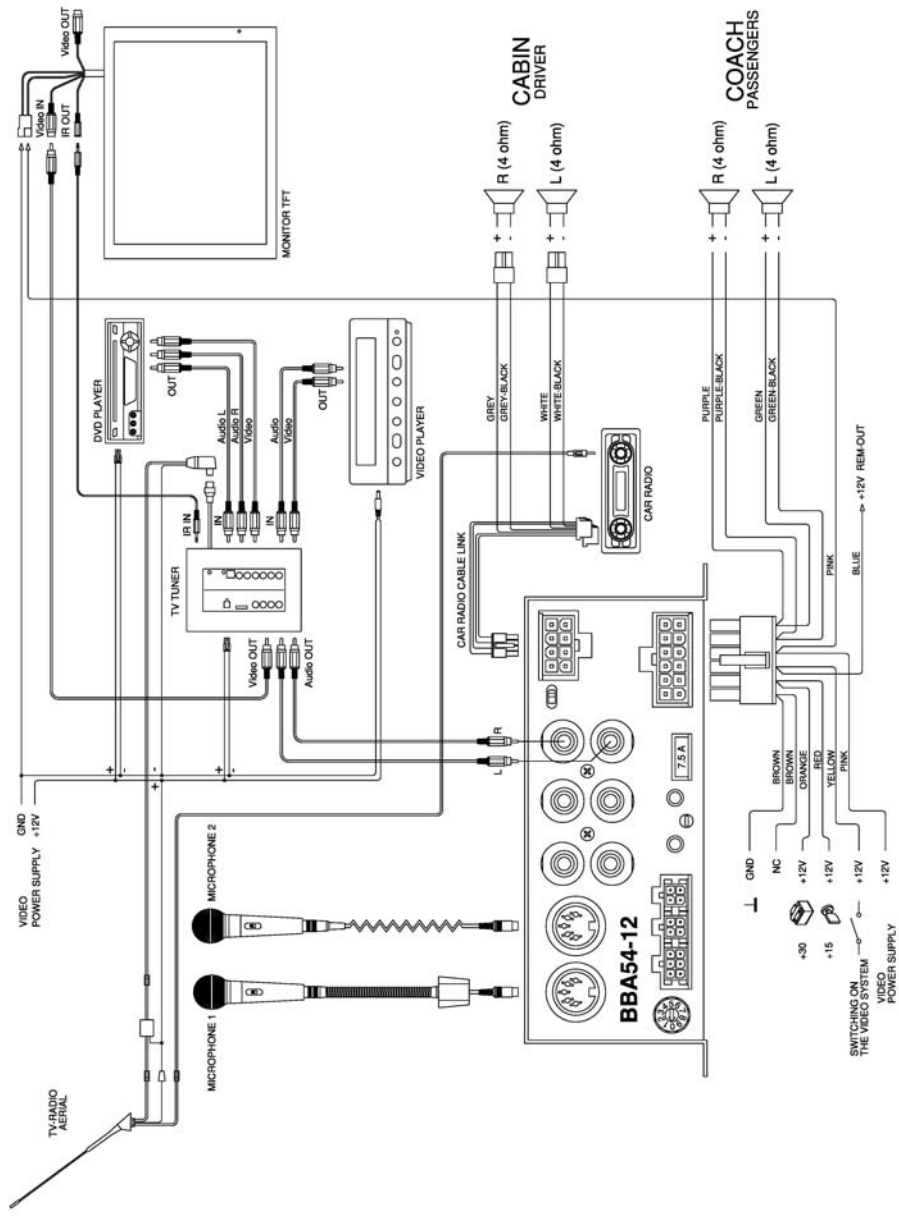

BBA54 24V

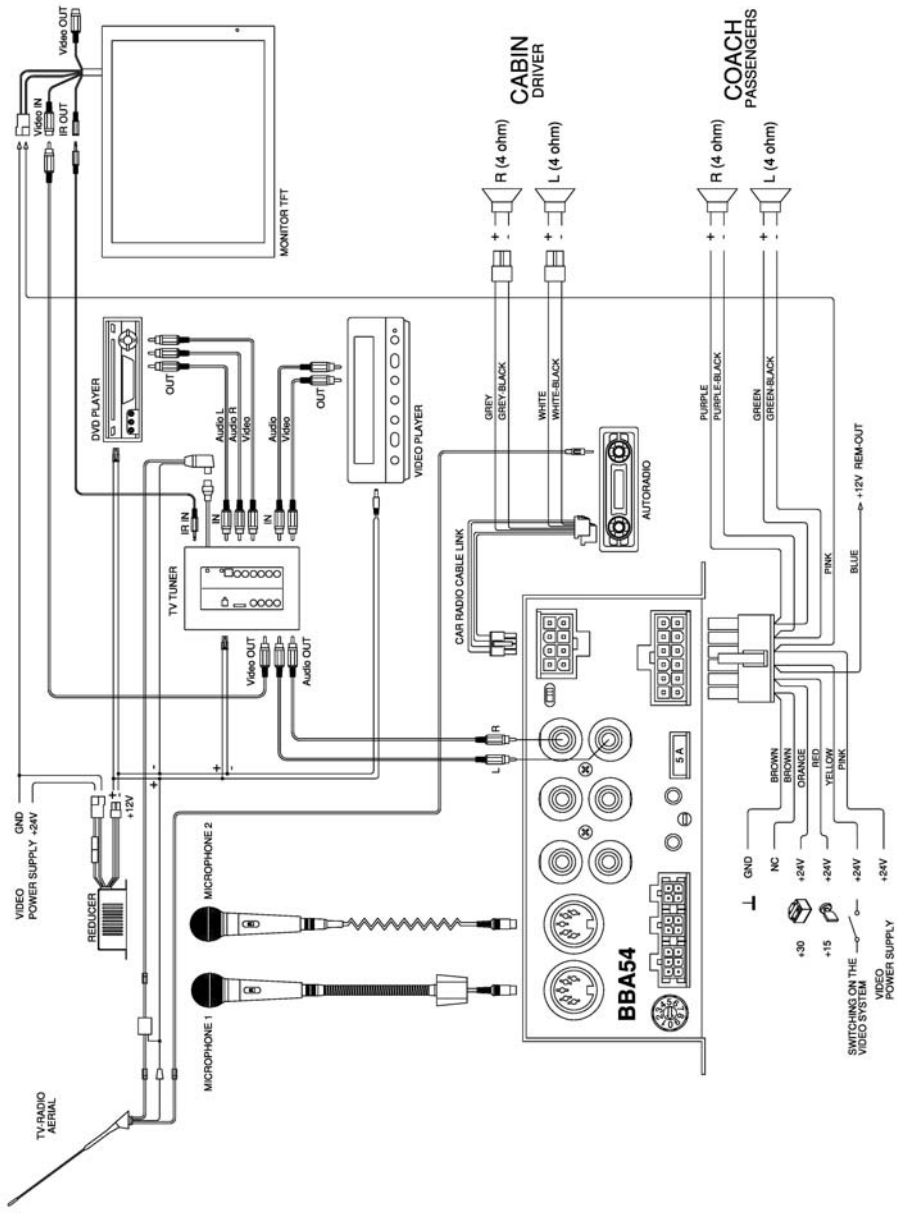

BBA54-12 12V + BBT54

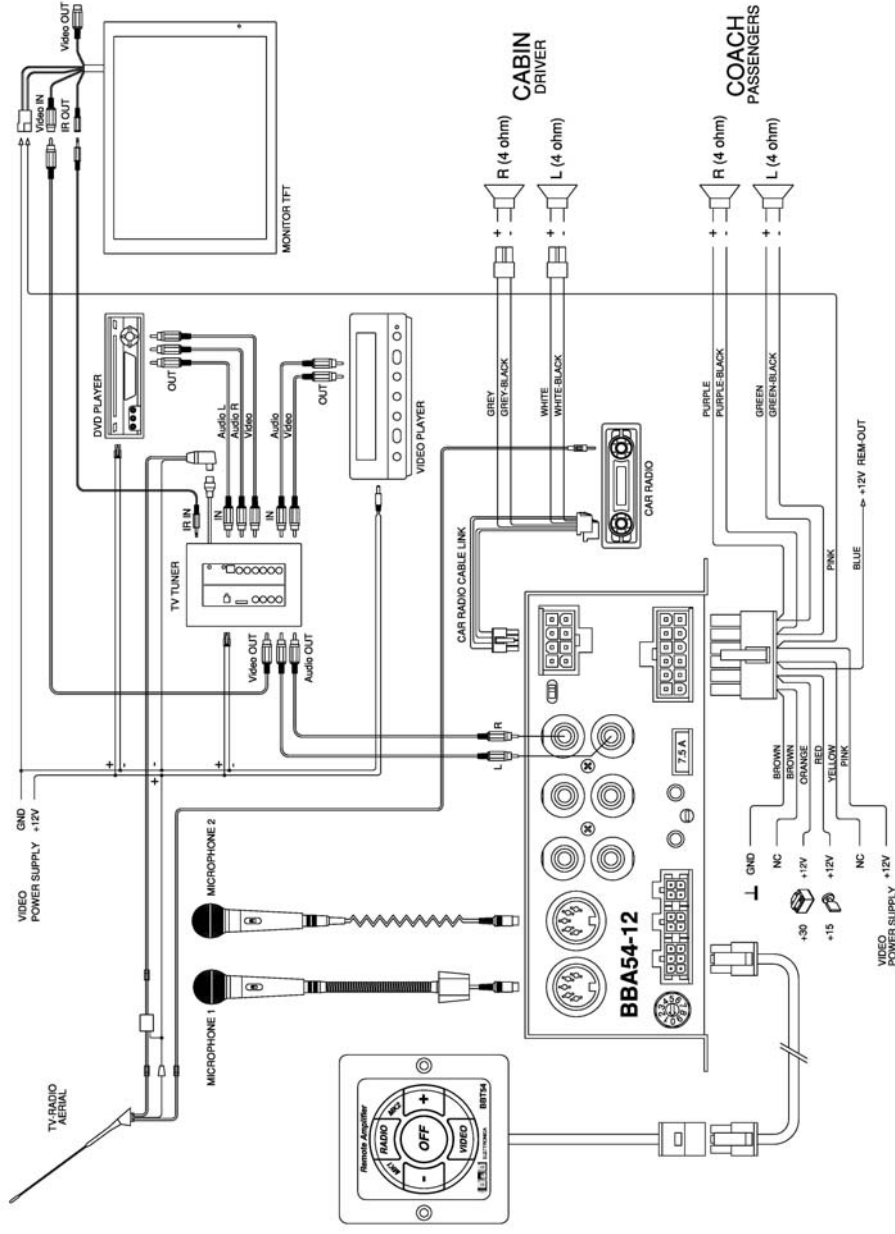

BBA54 24V + BBT54

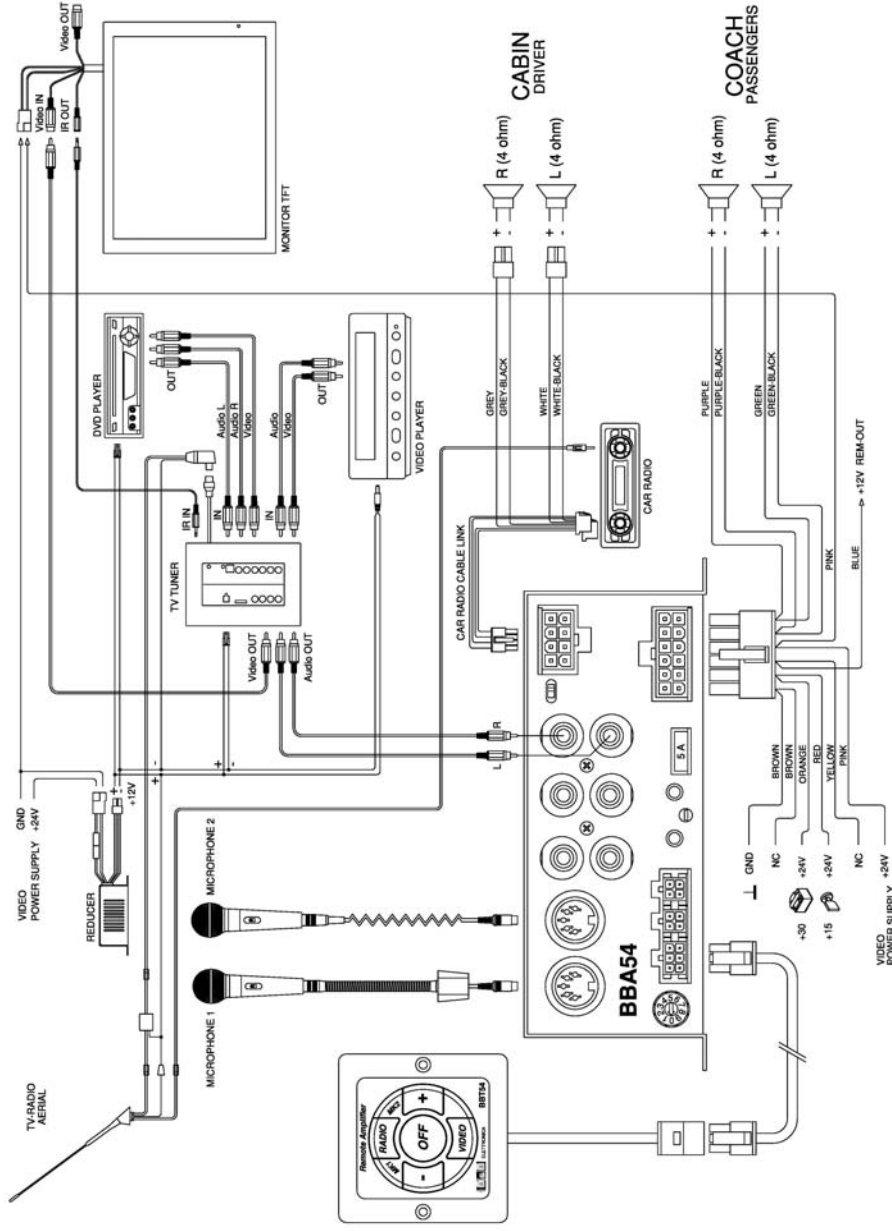

EXSAMPLE OF CASCADE CONNECTION

